

Kingspan Insulation Limited

Pembridge
Leominster
Herefordshire HR6 9LA

Tel: 01544 388601 Fax: 01544 388888
e-mail: info@kingspaninsulation.co.uk
website: www.kingspaninsulation.co.uk



Agrément Certificate
16/5299
Product Sheet 7

KINGSPAN KOOLTHERM RANGE FOR FLOORS, WALLS AND PITCHED ROOFS

KOOLTHERM K103 FLOORBOARD

This Agrément Certificate Product Sheet⁽¹⁾ relates to Kooltherm K103 Floorboard, comprising rigid phenolic board for use on ground-supported concrete or suspended timber or beam-and-block concrete ground floors. The product is also suitable for use between the joists of suspended timber ground floors and with exposed or semi-exposed intermediate concrete or timber floors, in new or existing domestic or similar buildings.

(1) Hereinafter referred to as 'Certificate'.

CERTIFICATION INCLUDES:

- factors relating to compliance with Building Regulations where applicable
- factors relating to additional non-regulatory information where applicable
- independently verified technical specification
- assessment criteria and technical investigations
- design considerations
- installation guidance
- regular surveillance of production
- formal three-yearly review.

KEY FACTORS ASSESSED

Thermal performance — the product has a declared thermal conductivity (λ_p value) of $0.018 \text{ W}\cdot\text{m}^{-1}\cdot\text{K}^{-1}$ (see section 6).

Condensation risk — the product can contribute to limiting the risk of condensation (see section 7).

Floor loading — the product, when installed in accordance with this Certificate, can support a design loading for domestic applications (see section 9).

Durability — the product is durable, rot proof, water resistant and sufficiently stable to remain effective as an insulation for the life of the building (see section 11).

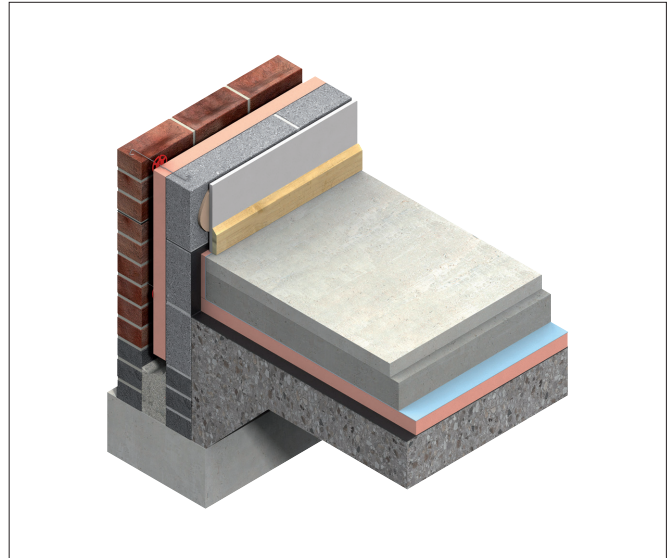

The BBA has awarded this Certificate to the company named above for the product described herein. This product has been assessed by the BBA as being fit for its intended use provided it is installed, used and maintained as set out in this Certificate.

On behalf of the British Board of Agrément

Date of First issue: 28 July 2016

John Albon — Head of Approvals
Construction Products

Claire Curtis-Thomas
Chief Executive

Certificate amended on 3 November 2021 to update sections 2.3 and 8.2.

The BBA is a UKAS accredited certification body – Number 113.

The schedule of the current scope of accreditation for product certification is available in pdf format via the UKAS link on the BBA website at www.bbacerts.co.uk

Readers MUST check the validity and latest issue number of this Agrément Certificate by either referring to the BBA website or contacting the BBA directly.

Any photographs are for illustrative purposes only, do not constitute advice and should not be relied upon.

British Board of Agrément

Bucknalls Lane
Watford
Herts WD25 9BA

©2016

tel: 01923 665300
clientservices@bbacerts.co.uk
www.bbacerts.co.uk

Regulations

In the opinion of the BBA, Kooltherm K103 Floorboard, if installed, used and maintained in accordance with this Certificate, can satisfy or contribute to satisfying the relevant requirements of the following Building Regulations (the presence of a UK map indicates that the subject is related to the Building Regulations in the region or regions of the UK depicted):



The Building Regulations 2010 (England and Wales) (as amended)

Requirement: A1	Loading
Comment:	The product can contribute to satisfying this Requirement. See section 9.2 of this Certificate.
Requirement: C2(c)	Resistance to moisture
Comment:	The product can contribute to satisfying this Requirement. See sections 7.1 and 7.5 of this Certificate.
Requirement: L1(a)(i)	Conservation of fuel and power
Comment:	The product can contribute to satisfying this Requirement. See section 6 of this Certificate.
Regulation: 7	Materials and workmanship
Comment:	The product is acceptable. See section 11 and the <i>Installation</i> part of this Certificate.
Regulation: 26	CO₂ emission rates for new buildings
Regulation: 26A	Fabric energy efficiency rates for new dwellings (applicable to England only)
Regulation: 26A	Primary energy consumption rates for new buildings (applicable to Wales only)
Regulation: 26B	Fabric performance values for new dwellings (applicable to Wales only)
Comment:	The product can contribute to satisfying these Regulations. See section 6 of this Certificate.



The Building (Scotland) Regulations 2004 (as amended)

Regulation: 8(1)	Durability, workmanship and fitness of materials
Comment:	The product is acceptable. See section 11 and the <i>Installation</i> part of this Certificate.
Regulation: 9	Building standards applicable to construction
Standard:	1.1(b) Structure
Comment:	The product can contribute to satisfying this Standard, with reference to clause 1.1.1 ⁽¹⁾⁽²⁾ . See section 9.2 of this Certificate.
Standard:	3.15 Condensation
Comment:	The product can contribute to satisfying this Standard, with reference to clauses 3.15.1 ⁽¹⁾⁽²⁾ , 3.15.4 ⁽¹⁾⁽²⁾ and 3.15.5 ⁽¹⁾⁽²⁾ . See sections 7.1 and 7.6 of this Certificate.
Standard:	6.1(b) Carbon dioxide emissions
Standard:	6.2 Building insulation envelope
Comment:	The product can contribute to satisfying these Standards, with reference to clauses, or parts of, 6.1.1 ⁽¹⁾ , 6.1.6 ⁽¹⁾ , 6.2.1 ⁽¹⁾⁽²⁾ , 6.2.3 ⁽¹⁾⁽²⁾ , 6.2.4 ⁽¹⁾⁽²⁾ , 6.2.5 ⁽¹⁾⁽²⁾ , 6.2.6 ⁽¹⁾⁽²⁾ , 6.2.7 ⁽¹⁾ , 6.2.8 ⁽²⁾ , 6.2.9 ⁽¹⁾⁽²⁾ , 6.2.10 ⁽¹⁾ , 6.2.11 ⁽¹⁾⁽²⁾ , 6.2.12 ⁽²⁾ and 6.2.13 ⁽¹⁾⁽²⁾ . See section 6 of this Certificate.
Standard:	7.1(a)(b) Statement of sustainability
Comment:	The product can contribute to satisfying the relevant requirements of Regulation 9, Standards 1 to 6, and therefore will contribute to a construction meeting a bronze level of sustainability as defined in this Standard. In addition, the product can contribute to a construction meeting a higher level of sustainability as defined in this Standard, with reference to clauses 7.1.4 ⁽¹⁾⁽²⁾ [Aspects 1 ⁽¹⁾⁽²⁾ and 2 ⁽¹⁾], 7.1.6 ⁽¹⁾ [Aspects 1 ⁽¹⁾⁽²⁾ and 2 ⁽¹⁾] and 7.1.7 ⁽¹⁾⁽²⁾ [Aspect 1 ⁽¹⁾⁽²⁾]. See section 6.1 of this Certificate.
Regulation: 12	Building standards applicable to conversions
Comment:	Comments in relation to the product under Regulation 9, Standards 1 to 6, also apply to this Regulation, with reference to clause 0.12.1 ⁽¹⁾ and Schedule 6 ⁽¹⁾ . (1) Technical Handbook (Domestic). (2) Technical Handbook (Non-Domestic).



The Building Regulations (Northern Ireland) 2012 (as amended)

Regulation: 23	Fitness of materials and workmanship
Comment:	The product is acceptable. See section 11 and the <i>Installation</i> part of this Certificate.
Regulation: 29	Condensation
Comment:	The product can contribute to satisfying this Regulation. See section 7.1 of this Certificate.
Regulation: 30	Stability
Comment:	The product can contribute to satisfying this Regulation. See section 9.2 of this Certificate.
Regulation: 39(a)(i)	Conservation measures
Regulation: 40(2)	Target carbon dioxide Emissions Rate
Comment:	The product can contribute to a building satisfying these Regulations. See section 6 of this Certificate.

Information in this Certificate may assist the client, Principal Designer/CDM co-ordinator, designer and contractors to address their obligations under these Regulations.

See section: *3 Delivery and site handling (3.3)* of this Certificate.

Additional Information

NHBC Standards 2016

NHBC accepts the use of Kooltherm K103 Floorboard, provided it is installed, used and maintained in accordance with this Certificate, in relation to *NHBC Standards*, Chapter 5.1 *Substructure and ground bearing floors*.

Technical Specification

1 Description

Kooltherm K103 Floorboard comprises a phenolic core, with coated glass-tissue facing on both sides. The nominal characteristics of the product are shown in Table 1 of this Certificate.

Table 1 Nominal characteristics

length (mm)	2400
width (mm)	1200
thickness (mm)	25 to 150
edge profile	square
minimum compressive strength at 10% compression (kPa)	120
nominal density (kg·m ⁻³)	35

2 Manufacture

2.1 Raw materials are injected onto the lower facer on a conveyor belt. The exothermic reaction expands the foam, which then comes into contact with the upper facer. An automated process cures and cuts the product to the required size.

2.2 As part of the assessment and ongoing surveillance of product quality, the BBA has:

- agreed with the manufacturer the quality control procedures and product testing to be undertaken
- assessed and agreed the quality control operated over batches of incoming materials
- monitored the production process and verified that it is in accordance with the documented process
- evaluated the process for management of nonconformities
- checked that equipment has been properly tested and calibrated
- undertaken to carry out the above measures on a regular basis through a surveillance process, to verify that the specifications and quality control being operated by the manufacturer are being maintained.

2.3 The management system of Kingspan Insulation Limited has been assessed and registered as meeting the requirements of BS EN ISO 9001 : 2015 by CIBSE Certification Limited, Certificate number 0001QMS-0.

3 Delivery and site handling

3.1 The product is delivered to site in polythene shrink-wrapped packs incorporating a label with the manufacturer's trade name, product description and characteristics, and the BBA logo incorporating the number of this Certificate.

3.2 Ideally, the board must be protected from prolonged exposure to sunlight and should be stored either under cover or protected with opaque polythene. Where possible, packs should be stored inside. If outside, the boards should be raised above ground level, and not in contact with ground moisture.

3.3 The product must not be exposed to open flame or other ignition sources, or to solvents or other chemicals.

Assessment and Technical Investigations

The following is a summary of the assessment and technical investigations carried out on Kooltherm K103 Floorboard.

Design Considerations

4 Use

4.1 Kooltherm K103 Floorboard is effective in reducing the U value (thermal transmittance) of new or existing ground floors. The product is for use on ground-supported concrete or suspended timber or beam-and-block concrete ground floors. The product is also suitable for use between the joists of suspended timber ground floors and with exposed or semi-exposed intermediate concrete or timber floors, in new or existing domestic or similar buildings.

4.2 Ground-bearing floors should only be used where the depth of compacted fill is less than 600 mm and is defined as non-shrinkable. Shrinkable fills are defined as material containing more than 35% fine particles (silt and clay) and having a Plasticity Index of 10% or greater (shrinkable fills are susceptible to clay heave).

4.3 Ground-supported concrete floors incorporating the boards must include a suitable damp-proof membrane (dpm) laid in accordance with the relevant clauses of CP 102 : 1973 and/or BS 8215 : 1991 (see sections 12 and 13 of this Certificate). Suspended concrete or timber ground floors incorporating the boards must include a dpm or suitable ventilation of the sub-floor as appropriate.

4.4 The overlay to the board should be:

- a vapour control layer (VCL) (see section 7.3) and
- a cement-based floor screed of minimum 65 mm thickness, laid in accordance with the relevant clauses of BS 8204-1 : 2003 and/or BS 8204-2 : 2003, or
- a wood-based floor (eg tongue-and-groove plywood to BS EN 636 : 2012, flooring grade particle board (Types P5 to P7) to BS EN 312 : 2010 or oriented strand board (OSB) of type OSB/3 or OSB/4 to BS EN 300 : 2006) of a suitable thickness to be determined by a suitably competent and experienced individual, installed in accordance with DD CEN/TS 12872 : 2007 and BS EN 12871 : 2013, or
- a concrete slab to BS EN 1992-1-1 : 2004.

4.5 If present, mould or fungal growth should be treated prior to the application of the product.

5 Practicability of installation

The product is designed to be installed by a competent general builder, or a contractor, experienced with this type of product.

6 Thermal performance



6.1 Calculations of the thermal transmittance (U value) of a floor should be carried out in accordance with BS EN ISO 6946 : 1997, BS EN ISO 13370 : 1998 and BRE Report BR 443 : 2006 using the declared thermal conductivity (λ_D value) of $0.018 \text{ W}\cdot\text{m}^{-1}\cdot\text{K}^{-1}$ for the product.

6.2 The U value of a floor will depend on the thickness of the board, the perimeter/area (P/A) ratio and the floor type. Examples of U values are given in Table 2. This table is for guidance only; a detailed calculation should be carried out for each proposed application.

Table 2 Floor U values ($\text{W}\cdot\text{m}^{-2}\cdot\text{K}^{-1}$)

	U value ($\text{W}\cdot\text{m}^{-2}\cdot\text{K}^{-1}$)	Kooltherm K103 insulation thickness (mm)				
		P/A ratio				
		0.2	0.4	0.6	0.8	1.0
Ground-supported concrete floor ⁽¹⁾	0.13	75	100	110	115	115
	0.15	60	85	90	95	100
	0.20	35	55	65	70	70
	0.22	25	45	55	60	65
	0.25	25	40	45	50	55
Suspended concrete ground-floor ⁽²⁾	0.13	95	110	110	115	115
	0.15	75	90	95	100	100
	0.20	45	60	65	70	70
	0.22	40	55	60	60	65
	0.25	30	45	50	55	55
Suspended timber ground-floor ⁽³⁾	0.13	145	160 (80 + 80)	180 (100 + 80)	185 (110 + 75)	195 (120 + 75)
	0.15	100	145	150	150	150
	0.20	55	95	95	100	105
	0.22	45	75	90	95	100
	0.25	30	55	65	70	75

(1) Ground-supported concrete floor construction (Kooltherm K103 insulation on top of slab, under screed finish) — 65 mm concrete screed $\lambda = 1.15 \text{ W}\cdot\text{m}^{-1}\cdot\text{K}^{-1}$, polyethylene separating layer, insulation, dpm, 100 mm concrete oversite, 150 mm sand-blinded hardcore. 25 mm thick x 65 mm deep K103 used as edge insulation.

(2) Suspended concrete ground-floor construction (Kooltherm K103 insulation on top of beam-and-block, below screed finish) — 65 mm concrete screed $\lambda = 1.15 \text{ W}\cdot\text{m}^{-1}\cdot\text{K}^{-1}$, polyethylene separating layer, insulation, beam-and-block floor (12%) beam $\lambda = 2.00 \text{ W}\cdot\text{m}^{-1}\cdot\text{K}^{-1}$, dense block infill $\lambda = 1.13 \text{ W}\cdot\text{m}^{-1}\cdot\text{K}^{-1}$, ventilated void.

(3) Suspended timber ground-floor construction (Kooltherm K103 insulation between floor joists) — floor deck thermal resistance $0.169 \text{ m}^2\cdot\text{K}\cdot\text{W}^{-1}$ based on 22 mm chipboard $\lambda = 0.13 \text{ W}\cdot\text{m}^{-1}\cdot\text{K}^{-1}$, insulation (87%) between 47 mm wide joists at 400 mm centres. The depth of the joists = 100 mm, 150 mm or 200 mm depending on the depth of insulation between floor joists (13%) based on BRE Report BR 443 : 2006 (38 mm-wide noggin every 3 metres).

Junctions



6.3 Care must be taken in the overall design and construction of junctions with other elements and openings to minimise thermal bridges and air infiltration. Detailed guidance can be found in the documents supporting the national Building Regulations.

7 Condensation risk

Interstitial condensation



7.1 Floors will adequately limit the risk of interstitial condensation when they are designed and constructed in accordance with BS 5250 : 2011, Annex F and the relevant guidance.

7.2 For the purposes of assessing the risk of interstitial condensation, the insulation core vapour resistance may be taken as approximately $18.5 \text{ MN}\cdot\text{s}\cdot\text{g}^{-1}$.

7.3 When the product is used above the dpm on a ground-supported floor or on a suspended concrete floor, a VCL is installed on the warm side of the insulation to inhibit the risk of interstitial condensation, unless a construction-specific risk assessment shows this is not necessary.

7.4 For a timber suspended ground floor, it is not necessary to introduce a VCL as long as adequate sub-floor cross ventilation is provided.

Surface condensation



7.5 Floors will adequately limit the risk of surface condensation when the thermal transmittance (U value) does not exceed $0.7 \text{ W}\cdot\text{m}^{-2}\cdot\text{K}^{-1}$ at any point, and the junctions with walls are designed in accordance with section 6.3 of this Certificate.



7.6 Floors will adequately limit the risk of surface condensation when the thermal transmittance (U value) does not exceed $1.2 \text{ W}\cdot\text{m}^{-2}\cdot\text{K}^{-1}$ at any point. Guidance may be obtained from BS 5250 : 2011 Annex F. Further guidance may be obtained from BRE Report BR 262 : 2002 and section 6.3 of this Certificate.

8 Behaviour in relation to fire

8.1 The product has an NPD classification (No Performance Determined).

8.2 When properly installed, the boards will not add significantly to any existing fire hazard. The boards will be contained within the floor by the overlay until the overlay itself is destroyed.

9 Floor loading

9.1 The compressive strength of the product (compressive stress at 10% deformation to BS EN 826 : 2013) is 120 kPa.



9.2 The product is suitable for domestic occupancies defined in this Certificate when covered with a suitable floor overlay (see section 4.4), and is capable of resisting a uniformly distributed load of $1.5 \text{ kN}\cdot\text{m}^{-2}$ or a concentrated load of 2 kN for category A1 and A2 (domestic) situations as defined in National Annex Table NA.2, BS EN 1991-1-1 : 2002. Further assessment by a suitably competent and experienced individual is necessary in the case of duty walkways and floors subject to physical activities.

9.3 The performance of the floor construction will depend on the insulation properties and type of floor overlay used (including thickness and strength). Where the product is used under a concrete slab, resistance to concentrated and distributed loads is a function of the slab specification. Further guidance on the suitability of floor overlays can be found in BS EN 13810-1 : 2002, DD CEN/TS 13810-2 : 2003, BS 8204-1 : 2003 and BS EN 312 : 2010, and from the flooring manufacturer.

10 Maintenance

As the product is confined within the floor by the overlay and has suitable durability (see section 11), maintenance is not required.

11 Durability



The product is durable, rot proof, water resistant and sufficiently stable to remain effective as an insulation for the life of the building in which it is incorporated.

Installation

12 General

12.1 Installation of Kooltherm K103 Floorboard must be in accordance with the Certificate holder's installation instructions and the requirements of this Certificate.

12.2 Typical methods are shown in Figures 1 to 4. Reference should also be made to BRE Report BR 262 : 2002.

12.3 All concrete floor surfaces should be smooth, level and flat to within 5 mm when measured with a 2 metre straight-edge. Irregularities greater than this must be removed. Minor irregularities (up to 10 mm deep) may be levelled with mortar or thin screed.

12.4 In ground-supported concrete floors, the concrete floor slab over which the boards are laid should be left for as long as possible to maximise drying out and dissipation of constructional moisture, in accordance with BS 8203 : 2001, Section 3.1.12.

12.5 Where the boards are used over ground-supported concrete floor slabs, a suitable dpm in accordance with CP 102 : 1973, Section 11 and BS 8204-1 : 2003 or BS 8204-2 : 2003 should be laid to resist moisture from the ground. If a liquid-type dpm is applied to the slabs, it should be of a type compatible with the boards and be allowed to dry out fully prior to installation of the boards.

Figure 1 Ground-supported concrete floor — screed overlay

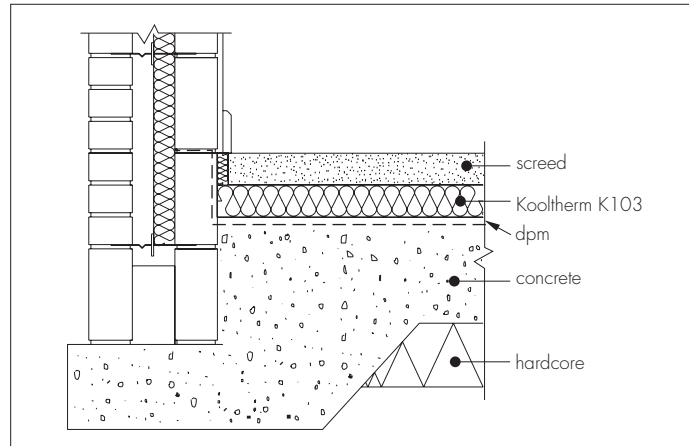

Figure 2 Suspended concrete floor — screed overlay

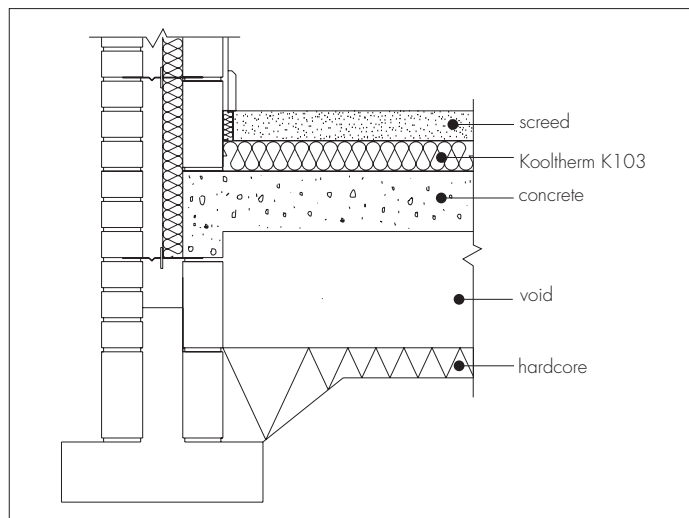

Figure 3 Concrete slab overlay

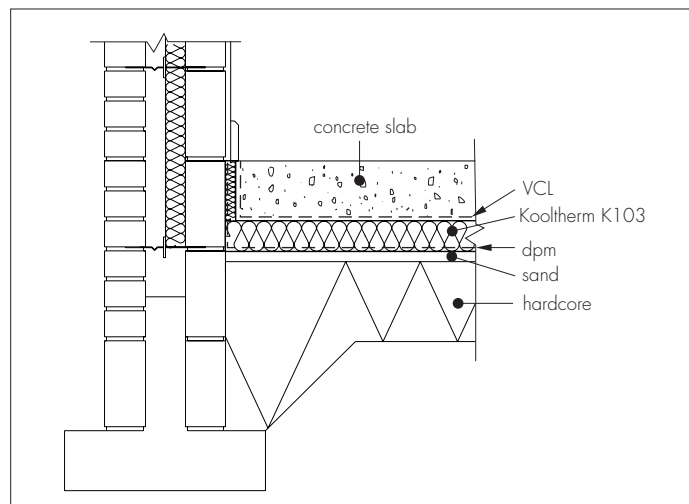
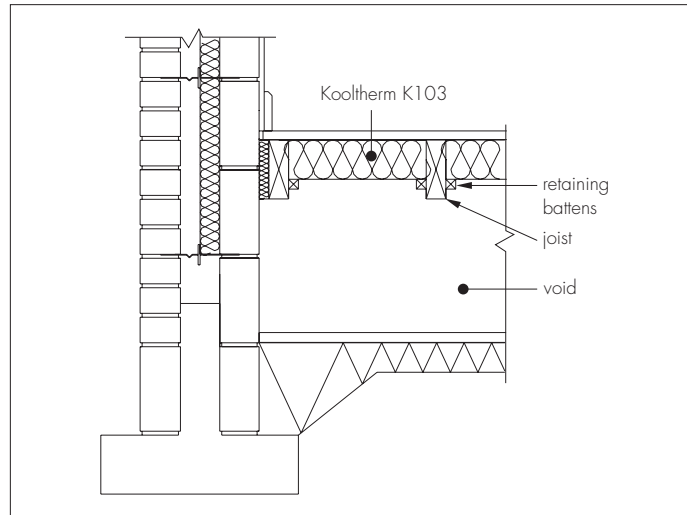

Figure 4 Suspended timber floors



12.6 Where the boards are used on hardcore bases under ground-supported concrete slabs, the hardcore must be compacted and blinded with a thin layer of sand before application of the dpm and boards.

12.7 The boards can be used on beam-and-block suspended concrete floors that are the subject of a current Agrément Certificate and installed in accordance with, and within the limitations imposed by, that Certificate, or floors designed and installed to the precast concrete and general loading codes that have been assessed as suitable.

12.8 Where a screed or concrete slab is laid over the product, vertical upstands of insulation should be provided and be of sufficient depth to fully separate the screed or slab from the wall and provide a minimum thermal resistance of $0.75 \text{ m}^2 \cdot \text{K} \cdot \text{W}^{-1}$. Alternatively, a suitable partial-fill cavity wall insulation material can be extended below the damp-proof course (dpc) level to provide edge insulation to the floor.

12.9 In suspended timber floors, the insulation boards are installed between the floor joists.

12.10 To limit the risk of damage from condensation and other sources of dampness, the boards and overlays should only be laid after the construction is made substantially weathertight, eg after glazing. During construction, the boards must also be protected from water spillage, plaster droppings and traffic.

12.11 The boards can be cut using a sharp knife or fine-toothed saw to fit around service penetrations.

13 Procedure

13.1 The boards are cut to size, as necessary, and laid with closely-butted, staggered cross-joints, ensuring that all spaces are completely filled.

13.2 The laying pattern should ensure that all cut edges are at the perimeter of the floor or some other feature (eg mat wells, thresholds or access ducts). Spreader boards should be used to protect the boards.

Cement-based screed overlay

13.3 Perimeter edge pieces are cut and placed around the edges and all floor joints taped, or a polyethylene VCL, minimum 0.125 mm thick, is laid over the boards with 150 mm laps. A properly-compacted screed is laid, of a minimum 65 mm thickness in domestic buildings, and 75 mm in other buildings. The relevant clauses of BS 8204-1 : 2003 or BS 8204-2 : 2003 should be followed and BRE's *Building Elements, Floors & Flooring*, Chapter 4.2, consulted.

Concrete slab overlay (ground-bearing only)

13.4 Perimeter edge pieces are cut and placed around the edges and taped at joints. A VCL, minimum 0.125 mm thick, is laid over the boards with 150 mm laps. The concrete slab is laid to the required thickness in accordance with BS 8000-9 : 2003 and BS 8204-1 : 2003.

Suspended timber floors

13.5 Boards are cut to fit tightly between joists. Small gaps should be insulated with cut strips of insulation.

13.6 The boards may be retained by preservative-treated timber battens, wide enough to retain the boards in place, and secured with corrosion-protected nails.

14 Incorporation of services

14.1 The maximum continuous working temperature of boards is 100°C . De-rating of electrical cables should be considered where the insulation restricts air cooling of cables.

14.2 Where the boards are installed on a floor of a suspended beam and block design, all services must be installed in accordance with the Agrément Certificate for that floor and/or with the relevant current codes of practice.

14.3 Where possible, electrical conduits, gas and water pipes or other services should be contained within ducts or channels within the concrete slab. Where this is not possible, the services may be accommodated within the insulation,

provided they are securely fixed to the concrete slab. Electrical cables should be enclosed in a suitable conduit. With hot pipes, the insulation must be cut back to maintain an air space.

14.4 Where water pipes are installed below the insulation, they should be pre-lagged. Generally, insulation will be relatively thin so it would not be possible to install pipes within the insulation. Pipes installed above the insulation will not require lagging, although some provision needs to be made for expansion and contraction.

14.5 On board overlay floors, in situations where access to the services is desirable, a duct may be formed by mechanically fixing to the floor timber bearers of the same thickness as the insulation to provide support for a particle board cover. The duct should be as narrow as possible and not exceed 400 mm in width or the maximum particle board spans given in DD ENV 12872 : 2000 without intermediate support. Services should be suitably fixed to the floor base and not to the insulation boards (see section 6.3 with regard to limiting heat loss).

Technical Investigations

15 Investigations

15.1 The manufacturing process was evaluated, including the methods adopted for quality control, and details were obtained of the quality and composition of the materials used.

15.2 An examination was made of test data relating to:

- dimensions
- load/deflection characteristics
- thermal conductivity
- U value calculation
- creep characteristics
- compressive strength
- condensation analysis.

Bibliography

BS 5250 : 2002 *Code of practice for control of condensation in buildings*

BS 8000-9 : 2003 *Workmanship on building sites — Cementitious levelling screeds and wearing screeds — Code of practice*

BS 8203 : 2001 *Code of practice for installation of resilient floor coverings*

BS 8204-1 : 2003 *Screeds, bases and in-situ floorings — Concrete bases and cement sand levelling screeds to receive floorings — Code of practice*

BS 8204-2 : 2003 *Screeds, bases and in-situ floorings — Concrete wearing surfaces — Code of practice*

BS 8215 : 1991 *Code of practice for design and installation of damp-proof courses in masonry construction*

BS EN 300 : 2006 *Oriented Strand Boards (OSB) — Definitions, classification and specifications*

BS EN 312 : 2010 *Particleboards — Specifications*

BS EN 636 : 2012 *Plywood — Specifications*

BS EN 826 : 2013 *Thermal insulating products for building applications — Determination of compression behaviour*

NA to BS EN 1991-1-1 : 2002 UK National Annex to *Eurocode 1 — Actions on structures. General actions. Densities, self-weight, imposed loads for buildings*

BS EN 1992-1-1 : 2004 *Eurocode 2: Design of concrete structures — General rules and rules for buildings*

BS EN 12871 : 2013 *Wood-based panels — Determination of performance characteristics for load bearing panels for use in floors, roofs and walls*

BS EN 13810-1 : 2002 *Wood-based panels — Floating floors — Performance specifications and requirements*

BS EN ISO 6946 : 1997 *Building components and building elements — Thermal resistance and thermal transmittance — Calculation method*

BS EN ISO 13370 : 1998 *Thermal performance of buildings — Heat transfer via the ground — Calculation methods*

CP 102 : 1973 *Code of practice for protection of buildings against water from the ground*

DD ENV 12872 : 2000 *Wood-based panels — Guidance on the use of load-bearing boards in floors, walls and roofs*

DD CEN 12872 : 2007 *Wood-based panels — Guidance on the use of load-bearing boards in floors, walls and roofs*

DD CEN/TS 13810-2 : 2003 *Wood-based panels — Floating floors — Test methods*

BRE Report (BR 262 : 2002) *Thermal insulation: avoiding risks*

BRE Report (BR 443 : 2006) *Conventions for U-value calculations*

16 Conditions

16.1 This Certificate:

- relates only to the product/system that is named and described on the front page
- is issued only to the company, firm, organisation or person named on the front page — no other company, firm, organisation or person may hold or claim that this Certificate has been issued to them
- is valid only within the UK
- has to be read, considered and used as a whole document — it may be misleading and will be incomplete to be selective
- is copyright of the BBA
- is subject to English Law.

16.2 Publications, documents, specifications, legislation, regulations, standards and the like referenced in this Certificate are those that were current and/or deemed relevant by the BBA at the date of issue or reissue of this Certificate.

16.3 This Certificate will remain valid for an unlimited period provided that the product/system and its manufacture and/or fabrication, including all related and relevant parts and processes thereof:

- are maintained at or above the levels which have been assessed and found to be satisfactory by the BBA
- continue to be checked as and when deemed appropriate by the BBA under arrangements that it will determine
- are reviewed by the BBA as and when it considers appropriate.

16.4 The BBA has used due skill, care and diligence in preparing this Certificate, but no warranty is provided.

16.5 In issuing this Certificate, the BBA is not responsible and is excluded from any liability to any company, firm, organisation or person, for any matters arising directly or indirectly from:

- the presence or absence of any patent, intellectual property or similar rights subsisting in the product/system or any other product/system
- the right of the Certificate holder to manufacture, supply, install, maintain or market the product/system
- actual installations of the product/system, including their nature, design, methods, performance, workmanship and maintenance
- any works and constructions in which the product/system is installed, including their nature, design, methods, performance, workmanship and maintenance
- any loss or damage, including personal injury, howsoever caused by the product/system, including its manufacture, supply, installation, use, maintenance and removal
- any claims by the manufacturer relating to CE marking.

16.6 Any information relating to the manufacture, supply, installation, use, maintenance and removal of this product/system which is contained or referred to in this Certificate is the minimum required to be met when the product/system is manufactured, supplied, installed, used, maintained and removed. It does not purport in any way to restate the requirements of the Health and Safety at Work etc. Act 1974, or of any other statutory, common law or other duty which may exist at the date of issue or reissue of this Certificate; nor is conformity with such information to be taken as satisfying the requirements of the 1974 Act or of any statutory, common law or other duty of care.