

## Kingspan Insulation Limited

Pembridge  
Leominster  
Herefordshire HR6 9LA

Tel: 01544 388601 Fax: 01544 388888  
e-mail: info@kingspaninsulation.co.uk  
website: www.kingspaninsulation.co.uk



**Agrément Certificate**

**16/5299**

Product Sheet 2

### KINGSPAN KOOLTHERM RANGE FOR FLOORS, WALLS AND PITCHED ROOFS

#### KOOLTHERM K106

This Agrément Certificate Product Sheet<sup>(1)</sup> relates to Kooltherm K106, comprising rigid phenolic (PF) foam boards with an outer facing of vapour-open polypropylene fleece and a composite (perforated) foil on the inner facing. For use as full fill thermal insulation (with a 10 mm residual cavity) in new external masonry cavity walls up to 25 metres in height in domestic and non-domestic buildings (additional requirements apply for buildings above 12 metres in height). The product is installed during construction.

(1) Hereinafter referred to as 'Certificate'.

(2) Kooltherm is a registered trademark

#### CERTIFICATION INCLUDES:

- factors relating to compliance with Building Regulations where applicable
- factors relating to additional non-regulatory information where applicable
- independently verified technical specification
- assessment criteria and technical investigations
- design considerations
- installation guidance
- regular surveillance of production
- formal three-yearly review.

#### KEY FACTORS ASSESSED

**Thermal performance** — the product has a declared thermal conductivity of  $0.018 \text{ W}\cdot\text{m}^{-1}\cdot\text{K}^{-1}$  (see section 6).

**Water resistance** — the product will resist the transfer of water across the cavity (see section 7).

**Condensation risk** — the product will contribute to limiting the risk of condensation (see section 8).

**Behaviour in relation to fire** — the product has a reaction to fire classification of Class F to BS EN 13501-1 : 2007 and is restricted in some cases (see section 9).

**Durability** — the product is durable, rot-proof, water-resistant and sufficiently stable to remain effective as insulation for the life of the building (see section 12).

The BBA has awarded this Certificate to the company named above for the product described herein. This product has been assessed by the BBA as being fit for its intended use provided it is installed, used and maintained as set out in this Certificate.

On behalf of the British Board of Agrément

Date of First issue: 1 March 2016

John Albon – Head of Approvals  
Construction Products

Claire Curtis-Thomas  
Chief Executive

*Certificate amended on 9 April 2019 to include Regulation 7(2) for England and associated text.*

*Certificate amended on 24 January 2020 to include new regulatory guidance for fire in Scotland and Wales.*

*Certificate amended on 3 November 2021 to update section 2.3.*

*The BBA is a UKAS accredited certification body – Number 113.*

*The schedule of the current scope of accreditation for product certification is available in pdf format via the UKAS link on the BBA website at www.bbacerts.co.uk*

*Readers MUST check the validity and latest issue number of this Agrément Certificate by either referring to the BBA website or contacting the BBA directly.*

*Any photographs are for illustrative purposes only, do not constitute advice and should not be relied upon.*

**British Board of Agrément**

Bucknalls Lane  
Watford  
Herts WD25 9BA

©2020

tel: 01923 665300  
clientservices@bbacerts.co.uk  
www.bbacerts.co.uk

## Regulations

In the opinion of the BBA, Kooltherm K106, if installed, used and maintained in accordance with this Certificate, can satisfy or contribute to satisfying the relevant requirements of the following Building Regulations (the presence of a UK map indicates that the subject is related to the Building Regulations in the region or regions of the UK depicted):



### The Building Regulations 2010 (England and Wales) (as amended)

<b>Requirement:</b>	<b>B3(4)</b>	<b>Internal fire spread (structure)</b>
Comment:		The product is restricted by this Requirement in some cases. See sections 9.1 and 9.3 of this Certificate.
<b>Regulation:</b>	<b>B4(1)</b>	<b>External fire spread</b>
Comment:		The product is restricted by this Requirement in some cases. See sections 9.1 and 9.3 of this Certificate.
<b>Requirement:</b>	<b>C2(a)</b>	<b>Resistance to moisture</b>
Comment:		The product can contribute to satisfying this Requirement. See section 7.1 of this Certificate.
<b>Requirement:</b>	<b>C2(b)</b>	<b>Resistance to moisture</b>
Comment:		The product can contribute to satisfying this Requirement. See section 7.2 of this Certificate.
<b>Requirement:</b>	<b>C2(c)</b>	<b>Resistance to moisture</b>
Comment:		The product can contribute to satisfying this Requirement. See sections 8.1 and 8.4 of this Certificate.
<b>Requirement:</b>	<b>L1(a)(i)</b>	<b>Conservation of fuel and power</b>
Comment:		The product can contribute to satisfying this Requirement. See section 6 of this Certificate.
<b>Regulation:</b>	<b>7(1)</b>	<b>Materials and workmanship</b>
Comment:		The product is acceptable. See section 12 and the <i>Installation</i> part of this Certificate.
<b>Regulation:</b>	<b>7(2)</b>	<b>Materials and workmanship</b>
Comment:		The product is restricted by this Regulation. See sections 9.1 and 9.2 of this Certificate.
<b>Regulation:</b>	<b>26</b>	<b>CO<sub>2</sub> emission rates for new buildings</b>
<b>Regulation:</b>	<b>26A</b>	<b>Fabric energy efficiency rates for new dwellings (applicable to England only)</b>
<b>Regulation:</b>	<b>26A</b>	<b>Primary energy consumption rates for buildings (applicable to Wales only)</b>
<b>Regulation:</b>	<b>26B</b>	<b>Fabric performance values for new dwellings (applicable to Wales only)</b>
Comment:		The product can contribute to satisfying these Regulations. See section 6 of this Certificate.



### The Building (Scotland) Regulations 2004 (as amended)

<b>Regulation:</b>	<b>8(1)</b>	<b>Durability, workmanship and fitness of materials</b>
Comment:		The product is acceptable. See section 12 and the <i>Installation</i> part of this Certificate.
<b>Regulation:</b>	<b>9</b>	<b>Building standards applicable to construction</b>
Standard:	<b>2.4</b>	Cavities
Comment:		The product is restricted under this Standard in some cases, with reference to clauses 2.4.2 <sup>(1)(2)</sup> , 2.4.1 <sup>(1)</sup> and 2.4.6 <sup>(2)</sup> . See sections 9.1, 9.4 and 9.5 of this Certificate.

Standard:	2.6	Spread to neighbouring buildings
Comment:		The product is restricted by this Standard in some cases with reference to clauses 2.6.5 <sup>(1)</sup> and 2.6.6 <sup>(2)</sup> . See sections 9.1 and 9.4 of this Certificate.
Standard:	3.4	Moisture from the ground
Comment:		The product can contribute to satisfying this Standard, with reference to clause 3.4.1 <sup>(1)(2)</sup> . See section 7.1 of this Certificate.
Standard:	3.10	Precipitation
Comment:		The product can contribute to satisfying this Standard, with reference to clause 3.10.1 <sup>(1)(2)</sup> , provided it complies with the conditions set out in section 7.2 of this Certificate.
Standard:	3.15	Condensation
Comment:		The product can contribute to satisfying this Standard, with reference to clauses 3.15.1 <sup>(1)(2)</sup> , 3.15.4 <sup>(1)(2)</sup> and 3.15.5 <sup>(1)(2)</sup> . See sections 8.1 and 8.5 of this Certificate.
Standard:	6.1(b)	Carbon dioxide emissions
Standard:	6.2	Building insulation envelope
Comment:		This product can contribute to satisfying clauses, or parts of, 6.1.1 <sup>(1)</sup> , 6.1.2 <sup>(2)</sup> , 6.1.6 <sup>(1)</sup> , 6.2.1 <sup>(1)(2)</sup> , 6.2.3 <sup>(1)</sup> , 6.2.4 <sup>(2)</sup> , 6.2.5 <sup>(2)</sup> , 6.2.9 <sup>(1)</sup> and 6.2.11 <sup>(2)</sup> of these Standards. See section 6 of this Certificate.
Standard:	7.1(a)(b)	Statement of sustainability
Comment:		The product can contribute to satisfying the relevant requirements of Regulation 9, Standards 1 to 6, and therefore will contribute to a construction meeting the bronze level of sustainability as defined in this Standard. In addition, the product can contribute to a construction meeting a higher level of sustainability as defined in this Standard with reference to clauses 7.1.4 <sup>(1)(2)</sup> [Aspect 1 <sup>(1)(2)</sup> and 2 <sup>(1)</sup> ], 7.1.6 <sup>(1)(2)</sup> [Aspect 1 <sup>(1)(2)</sup> and 2 <sup>(1)</sup> ] and 7.1.7 <sup>(1)(2)</sup> [Aspect 1 <sup>(1)(2)</sup> ]. See section 6.1 of this Certificate.
<b>Regulation:</b>	<b>12</b>	<b>Building standards applicable to construction</b>
Comment:		All comments made in relation to the product under Regulation 9, Standards 1 to 6, also apply to this Regulation, with reference to clause 0.12.1 <sup>(1)(2)</sup> and Schedule 6 <sup>(1)(2)</sup> .

(1) Technical Handbook (Domestic).  
(2) Technical Handbook (Non-Domestic).



## The Building Regulations (Northern Ireland) 2012 (as amended)

<b>Regulation:</b>	<b>23</b>	<b>Fitness of materials and workmanship</b>
Comment:		The product is acceptable. See section 12 and the <i>Installation</i> part of this Certificate.
<b>Regulation:</b>	<b>28(a)</b>	<b>Resistance to moisture and weather</b>
Comment:		The product can contribute to satisfying this Regulation. See section 7.1 of this Certificate.
<b>Regulation:</b>	<b>28(b)</b>	<b>Resistance to moisture and weather</b>
Comment:		The product can contribute to satisfying this Regulation. See section 7.2 of this Certificate.
<b>Regulation:</b>	<b>29</b>	<b>Condensation</b>
Comment:		The product can contribute to satisfying this Regulation. See section 8.1 of this Certificate.
<b>Regulation:</b>	<b>35(4)</b>	<b>Internal fire spread – structure</b>
Comment:		The product is restricted by this Regulation. See sections 9.1 and 9.3 of this Certificate.

<b>Regulation:</b>	<b>36(a)</b>	<b>External fire spread</b>
Comment:		The product is restricted by this Regulation in some cases. See sections 9.1 and 9.3 of this Certificate.
<b>Regulation:</b>	<b>39(a)(i)</b>	<b>Conservation measures</b>
<b>Regulation:</b>	<b>40(2)</b>	<b>Target carbon dioxide emission rate</b>
Comment:		The product can contribute to satisfying these Regulations. See section 6 of this Certificate.

## Construction (Design and Management) Regulations 2015 Construction (Design and Management) Regulations (Northern Ireland) 2007

Information in this Certificate may assist the client, designer (including Principal Designer) and contractor (including Principal Contractor) to address their obligations under these Regulations.

See section: 3 *Delivery and site handling* (3.3) of this Certificate.

### Additional Information

#### NHBC Standards 2016

NHBC accepts the use of Kooltherm K106, other than in very severe exposure locations with fair-faced masonry, provided it is installed, used and maintained in accordance with this Certificate, in relation to *NHBC Standards*, Chapter 6.1 *External masonry walls*.

#### CE marking

The Certificate holder has taken the responsibility of CE marking the product in accordance with harmonised European Standard BS EN 13166 : 2012. An asterisk (\*) appearing in this Certificate indicates that data shown are given in the manufacturer's Declaration of Performance.

### Technical Specification

#### 1 Description

1.1 Kooltherm K106 comprises rigid phenolic (PF) foam boards with an outer facing of vapour-open polypropylene fleece and a composite (perforated) foil on the inner facing.

1.2 The product has the nominal characteristics shown in Table 1.

Length* x width* (mm)	1200 x 450
Thickness* (mm)	40, 50, 55, 60, 65, 70, 75, 90, 100, 115
Density (kg·m <sup>-3</sup> )	40
Edge detail	Square

1.3 Ancillary items used with the boards include:

- 100 mm wide self-adhesive breathable tape.

#### 2 Manufacture

2.1 Raw materials are injected onto the lower foil-facer on a conveyor belt. The exothermic reaction expands the foam, which then comes into contact with the upper foil-facer. An automated process cures and cuts the product to the required size.

2.2 As part of the assessment and ongoing surveillance of product quality, the BBA has:

- agreed with the manufacturer the quality control procedures and product testing to be undertaken
- assessed and agreed the quality control operated over batches of incoming materials
- monitored the production process and verified that it is in accordance with the documented process
- evaluated the process for management of nonconformities
- checked that equipment has been properly tested and calibrated
- undertaken to carry out the above measures on a regular basis through a surveillance process, to verify that the specifications and quality control operated by the manufacturer are being maintained.

2.3 The management system of Kingspan Insulation Limited has been assessed and registered as meeting the requirements of BS EN ISO 9001 : 2015 by CIBSE Certification Limited, Certificate number 0001QMS-0.

### 3 Delivery and site handling

3.1 The boards are delivered to site in polythene-wrapped packs. Each pack contains a label bearing the manufacturer's name, board dimensions and the BBA logo incorporating the number of this Certificate.

3.2 The boards must be protected from prolonged exposure to sunlight, and stored dry, flat and raised above ground level (to avoid contact with ground moisture). Where possible, packs should be stored inside. If stored outside, they should be under cover, or protected with opaque polythene sheeting.

3.3 The boards are light and easy to handle; care should be exercised to avoid crushing the edges or corners. If damaged, the product should be discarded.

3.4 The boards must not be exposed to open flame or other ignition sources, or to solvents or other chemicals.

## Assessment and Technical Investigations

The following is a summary of the assessment and technical investigations carried out on Kooltherm K106.

### Design Considerations

#### 4 General

4.1 Kooltherm K106 is satisfactory for use as a full fill cavity wall insulation (with a 10 mm residual cavity) and is effective in reducing the thermal transmittance (U value) of external cavity walls with masonry inner and outer leaves (where masonry includes clay and calcium silicate bricks, concrete blocks, and natural and reconstituted stone blocks). The product is for use in new domestic and non-domestic buildings. It is essential that such walls are designed and constructed to incorporate the precautions given in this Certificate to prevent moisture penetration.

4.2 This Certificate covers the use of the product in any exposure zone. However, use of the product does not preclude the need to apply an external render coat or other suitable finish in severe exposure zones where such application would be normal practice.

4.3 As with other forms of cavity wall insulation, where buildings need to comply with *NHBC Standards 2016*, specifiers should observe the requirements of that document.

4.4 New buildings subject to the national Building Regulations should be constructed in accordance with the relevant recommendations of:

- BS EN 1996-1-1 : 2005, BS EN 1996-1-2 : 2005, BS EN 1996-2 : 2006 and BS EN 1996-3 : 2006 and their respective UK National Annexes
- BS EN 845-1 : 2013 and BS 8000-3 : 2001.

4.5 Other new buildings, not subject to regulatory requirements, should also be built in accordance with the Standards identified in section 4.4 of this Certificate.

4.6 Cavity wall ties with insulation-retaining fixings and, if required, any additional ties to BS EN 845-1 : 2013 and PD 6697 : 2010 should be used for structural stability in accordance with BS EN 1996-1-1 : 2005, BS EN 1996-2 : 2006 and BS EN 1996-3 : 2006.

4.7 Care must be taken in the overall design and construction of walls incorporating the product to ensure the provision of appropriate:

- cavity trays and damp-proof courses (dpc's)
- cavity barriers and fire dampers
- resistance to the ingress of precipitation, moisture and dangerous gases from the ground
- resistance to sound transmission when flanking separating walls and floors.

#### **Buildings over 12 m high and up to and including 25 m high**

4.8 Where the walls of a building are between 12 m and 25 m high, the following requirements also apply:

- from ground level, the maximum height of continuous cavity must not exceed 12 m. Above 12 m, the maximum height of a continuous cavity must not exceed 7 m. In both cases, breaks should be in the form of continuous horizontal cavity trays and weep holes discharging to the outside
- the area to be insulated must not be an infill panel in a framed structure
- the Certificate holder, in association with the architect, must carry out a detailed programme of assessment of the project, including an examination of the quality of installation as work progresses. Above average site supervision is recommended during installation.

## **5 Practicability of installation**

The product is designed to be installed by a competent general builder, or a contractor, experienced with this type of product.

## **6 Thermal performance**



6.1 Calculations of the thermal transmittance (U value) of specific external wall constructions should be carried out in accordance with BS EN ISO 6946 : 2007 and BRE Report BR 443 : 2006, using the declared thermal conductivity\* ( $\lambda_D$ ) of  $0.018 \text{ W}\cdot\text{m}^{-1}\cdot\text{K}^{-1}$ .

6.2 The U value of a completed wall will depend on the insulation thickness, number and type of fixings, the insulating value of the substrate masonry and its internal finish. Calculated U values for example constructions are given in Table 2.

**Table 2 Example U values<sup>(1)(2)</sup> — new buildings**

U value requirement (W·m <sup>-2</sup> ·K <sup>-1</sup> )	Insulation thickness (mm)	
	13 mm dense plaster <sup>(3)</sup> 100 mm dense block <sup>(4)</sup>	Plasterboard on dabs 100 mm AAC block <sup>(5)</sup>
0.13	—	115
0.14	115	—
0.15	115	100
0.16	100	90
0.18	90	75
0.19	90	70
0.25	65	50
0.26	60	50
0.27	60	50
0.28	55	50
0.30	50	40
0.35	50	40

(1) Assumes fixings correction for fully-penetrating stainless steel fixings (17 W·m<sup>-1</sup>·K<sup>-1</sup>) at 2.5 per m<sup>2</sup> with a cross-sectional area of 12.5 mm<sup>2</sup>, nominal U value and 102 mm thick brick outer leaf.

(2) An emissivity of 0.9 has been used for the polypropylene fleece outer facer, with respect to the 10 mm residual cavity.

(3) Plaster thermal conductivity of 0.57 W·m<sup>-1</sup>·K<sup>-1</sup>.

(4) Block and mortar thermal conductivity of 1.13 W·m<sup>-1</sup>·K<sup>-1</sup> and 0.88 W·m<sup>-1</sup>·K<sup>-1</sup> respectively.

(5) Block and mortar thermal conductivity of 0.12 W·m<sup>-1</sup>·K<sup>-1</sup> and 0.88 W·m<sup>-1</sup>·K<sup>-1</sup> respectively.

## Junctions

6.3 Care must be taken in the overall design and construction of junctions with other elements and openings to minimise thermal bridges and air infiltration. Detailed guidance can be found in the documents supporting the national Building Regulations.

## 7 Water resistance



7.1 The product can be used in situations where it bridges the dpc in walls; dampness from the ground will not pass through to the inner leaf provided the wall is detailed in accordance with the requirements and provisions of the national Building Regulations.

7.2 When the product is properly installed in accordance with this Certificate, it will resist any water transfer across the cavity to the inner leaf.

7.3 In all situations, it is particularly important to ensure during installation that:

- wall ties are installed correctly and are thoroughly clean
- excess mortar is cleaned from the cavity face of the leading leaf and any debris removed from the cavity
- mortar droppings are cleaned from the exposed edges of installed slabs
- insulation boards are properly installed and butt-jointed
- installation is carried out to the highest level on each wall, or the top edge of the insulation is protected by a cavity tray
- at lintel level, a cavity tray, stop ends and weep holes are provided
- cavity battens and/or boards are used during construction to prevent bridging by mortar droppings
- dpc's at ground level do not project into the cavity as they can form a trap for mortar bridging
- raked or recessed mortar joints are avoided in very severe exposure areas.

7.4 Window and door opening reveals should be constructed incorporating a cavity barrier/closer/dpc as required (see sections 13 and 14).

7.5 Wall corners are to be constructed incorporating a vertical dpc as noted in section 14.16.

## 8 Condensation

### Interstitial condensation



8.1 Walls will adequately limit the risk of interstitial condensation when they are designed and constructed in accordance with BS 5250 : 2011, Annexes D and G and the relevant guidance.

8.2 For the purposes of calculations, the vapour resistance value of the individual components may be taken as:

- phenolic insulation —  $18.5 \text{ MN}\cdot\text{s}\cdot\text{g}^{-1}$
- (perforated) foil facing —  $3 \text{ MN}\cdot\text{s}\cdot\text{g}^{-1}$
- vapour-open polypropylene fleece facing —  $0.25 \text{ MN}\cdot\text{s}\cdot\text{g}^{-1}$
- self-adhesive breathable tape —  $2.00 \text{ MN}\cdot\text{s}\cdot\text{g}^{-1}$ .

8.3 If the product is to be used in the external walls of rooms expected to have high humidity, care must be taken to provide adequate permanent ventilation to avoid possible problems from the formation of interstitial condensation in the internal wall leaf.

### Surface condensation



8.4 Walls will adequately limit the risk of surface condensation when the thermal transmittance (U value) does not exceed  $0.7 \text{ W}\cdot\text{m}^{-2}\cdot\text{K}^{-1}$  at any point and the junctions with other elements are designed in accordance with the guidance referred to in section 6.3 of this Certificate.



8.5 For buildings in Scotland, constructions will be acceptable where the thermal transmittance (U value) does not exceed  $1.2 \text{ W}\cdot\text{m}^{-2}\cdot\text{K}^{-1}$  at any point and the junctions with other elements are designed in accordance with the guidance referred to in BS 5250 : 2011, Annex G. Further guidance may be obtained from BRE Report BR 262 : 2002 and section 6.3 of this Certificate.

## 9 Behaviour in relation to fire



9.1 The product has a reaction to fire classification\* of Class F to BS EN 13501-1 : 2007. It is not classified as non-combustible or of limited combustibility.



9.2 In England and Wales, the product should not be used on buildings with a storey 18 m or more above ground level that contains: one or more dwellings, an institution, a room for residential purposes (excluding any room in a hostel, hotel or boarding house), student accommodation, care homes, sheltered housing, hospitals or dormitories in boarding schools.



9.3 In England, Wales and Northern Ireland, the product is unrestricted in terms of proximity to a boundary and, for constructions comprising two leaves of brick or concrete each at least 75 mm thick and with cavities closed around openings and at the top of the wall (with cavity barriers in Northern Ireland), is unrestricted in terms of height, other than those described in section 9.2. For other constructions, the product should not be used in buildings with a floor more than 18 m above the ground and cavity barriers must be provided.



9.4 In Scotland, the product may be used without restriction on height or proximity to a relevant boundary, provided it is installed in a cavity that is between two leaves of masonry at least 75 mm thick, and which has a cavity barrier around all openings in the wall and at the top of the wall head. For other constructions, the product should not be used 1 m or less from a boundary or in a building with a floor more than 11 m above the ground and cavity barriers must be provided.

9.5 In Scotland, the product does not achieve the minimum Class E reaction to fire classification to BS EN 13501-1: 2018 required by Technical Handbook clauses 2.4.2 so designers should seek guidance on the proposed use of the product/system from the relevant building control body.



9.6 Designers should refer to the relevant national Building Regulations and guidance for detailed conditions of use, particularly in respect of requirements for substrate fire performance, cavity closers and barriers, fire stopping of service penetrations and combustibility limitations for other materials and components used in the overall wall construction.

## 10 Proximity of flues and appliances

When installing the product in close proximity to certain flue pipes and/or heat-producing appliances, the relevant provisions of the national Building Regulations are applicable:

**England and Wales** — Approved Document J, sections 1 to 4

**Scotland** — Mandatory Standard 3.19, clauses 3.19.1<sup>(1)(2)</sup> to 3.19.9<sup>(1)(2)</sup>

(1) Technical Handbook (Domestic).

(2) Technical Handbook (Non-Domestic).

**Northern Ireland** — Technical Booklet L, sections 1 to 6.

## 11 Maintenance

As the product is confined within the wall cavity and has suitable durability (see section 12), maintenance is not required.

## 12 Durability



The product is durable, rot-proof, water-resistant and sufficiently stable to remain effective as insulation for the life of the building.

## Installation

### 13 General

13.1 The Certificate holder will provide on-site demonstrations on request, to ensure correct installation from the outset.

13.2 Adequate supervision of the installation should be maintained and the Certificate holder's specialists must have right of access to the site to ensure correct installation.

13.3 It is recommended that the internal leaf is constructed ahead of the external leaf so that any mortar protruding into the cavity space from the back of the internal leaf can be cleaned off before installing the product. Boards must not be pushed into a completed cavity.

13.4 Vertical joints in the boards must be staggered and all joints tightly butted. Where protrusions occur in the cavity, the boards should be carefully cut to fit.

13.5 If installation of the boards is terminated below the highest level of the wall, the top edge of the insulation must be protected by a cavity tray and alternate perpend joints raked out to provide adequate drainage of water from the tray.

13.6 Where required, door and window reveals should incorporate a suitable cavity barrier/closer (see Figure 5). It is recommended that BBA-approved cavity closers are used.

13.7 Wall corners must be constructed in accordance with section 14.16 and must incorporate a vertical dpc as shown in Figure 8.

13.8 All vertical and horizontal board joints, board edges and abutting junction interfaces must be taped using the self-adhesive breathable tape.

## 14 Procedure

14.1 A section of the internal leaf is built in the conventional manner, with the first row of wall ties, at approximately 600 mm horizontal spacing, where the insulation is to begin. The wall ties should not be placed directly on the dpc. The first run of boards should commence at least 150 mm below the dpc level (or 200 mm for suspended timber floors), to provide some edge insulation for the floor (see Figure 1).

Figure 1 First row of boards at dpc level

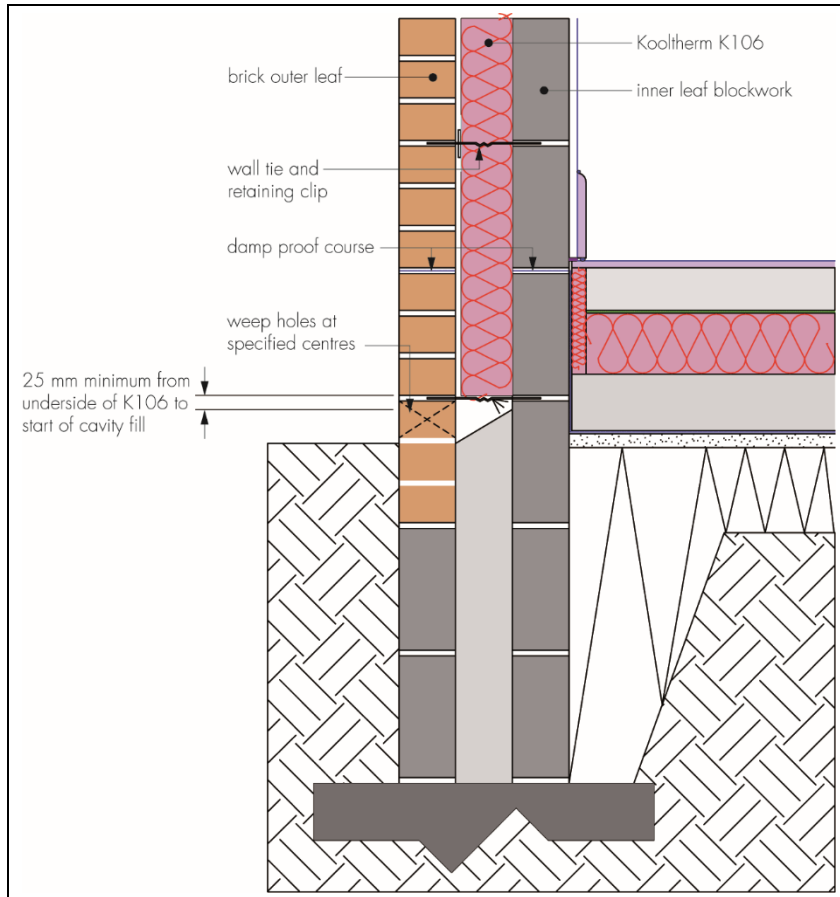

14.2 The internal leaf is then built up to a course above the next row of wall ties, which are placed at a vertical spacing of 450 mm and not more than 900 mm horizontally (see BS EN 1996-1-2 : 2005). Excess mortar should be cleaned from the cavity face of the internal leaf.

14.3 Boards are placed between the upper and lower wall ties, behind the retaining clips, to form a closely butt-jointed run. It is essential that all wall ties slope downwards towards the external leaf, with the drip positioned in the centre of the boards pointing downwards to shed water away from the internal leaf (see Figure 2). Wall ties must not be placed at centres exceeding 900 mm to ensure that each board is secured at a minimum of three points. It is also important that the first row of boards should not be in contact with the ground, with a gap of at least 25 mm between the bottom edge of the insulation and the cavity fill.

Figure 2 Wall tie drips positioned in centre of boards

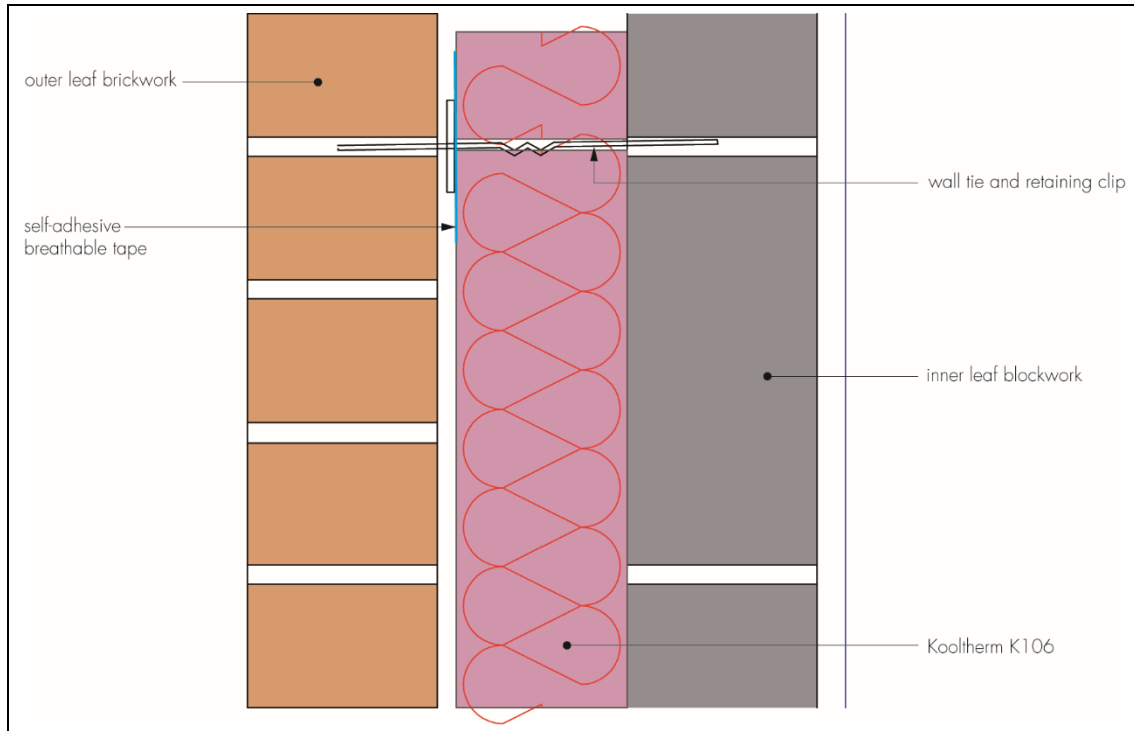

14.4 A self-adhesive breathable tape, no less than 100 mm wide, should be applied in a smooth and wrinkle-free manner and should extend no less than 50 mm to all horizontal and vertical board joints, board edges and abutting junction interfaces (see Figure 3). If necessary, additional layers of tape may be applied. The seal must be maintained at protrusion locations, eg wall ties.

Figure 3 Self-adhesive breathable tape applied to boards

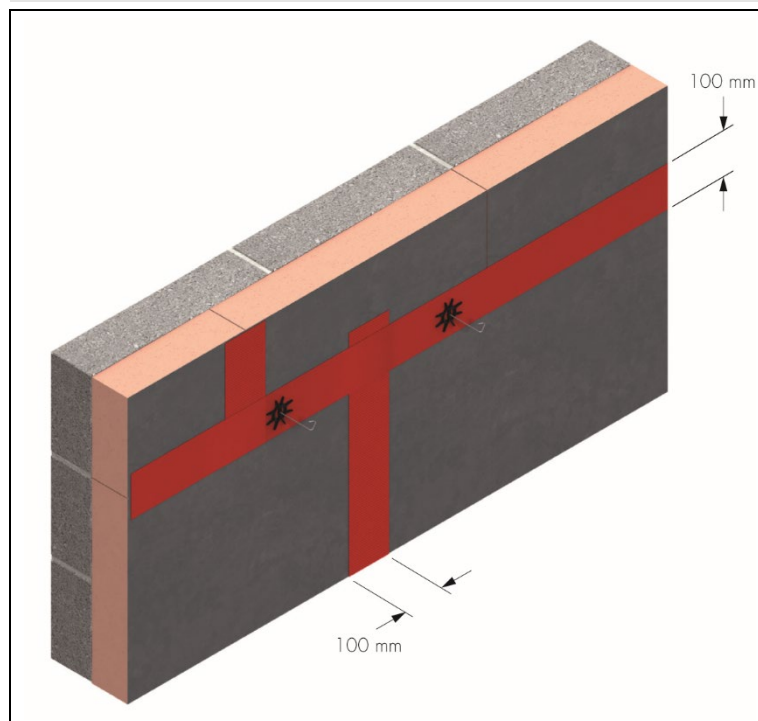

14.5 To ensure successful adhesion, all surfaces to receive the tape should be made clean, dry and free from grease, dust, dirt and all other foreign matter prior to application. A gentle pressure may also be exerted during application.

14.6 The external leaf is built up to the same level as the boards, maintaining a 10 mm residual cavity in order to aid installation and accommodate mortar squeeze.

14.7 Successive sections of wall, incorporating wall ties, are constructed and the boards installed as work proceeds up to the required height.

14.8 Additional ties may be required to satisfy the structural requirements of BS EN 845-1 : 2013, BS EN 1996-1-1 : 2005, BS EN 1996-2 : 2006 and BS EN 1996-3 : 2006 to ensure adequate retention of boards or cut pieces.

14.9 All boards should be butted with vertical joints staggered. Insulation boards and wall ties should be staggered as construction proceeds and carried up to the highest level of wall, except where protected by a cavity tray.

### Mortar droppings

14.10 After each section of the wall leaf is built, excess mortar should be removed from the cavity face and mortar droppings cleaned from exposed edges of the installed board before installation of the next section. Use of a cavity board and cavity timber stop is recommended to protect installed board edges and help keep the cavity clean as the following leaf is built (see Figure 4).

Figure 4 Use of cavity board/timber stop when cleaning off excess mortar

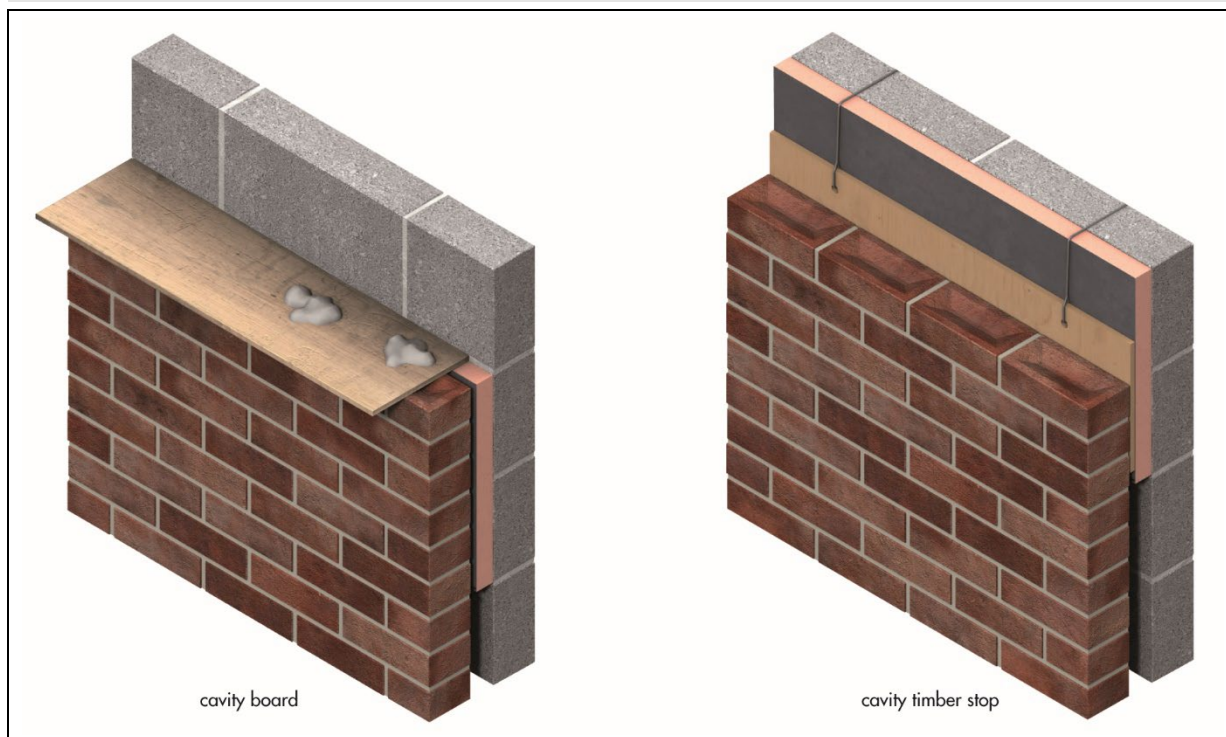

14.11 The boards can be cut, using a sharp knife or fine-toothed saw, to fit openings, eg around windows, doors and airbricks. It is essential that cut pieces completely fill the spaces for which they are intended and are adequately secured.

### Wall openings

14.12 Where openings such as doors and windows are in close proximity, it is recommended that a continuous lintel or cavity tray is used. Individual lintels or cavity trays should have stop-ends and be adequately drained.

14.13 Proprietary cavity barriers/closers must be correctly installed at window and door reveals (see Figure 5).

Figure 5 Reveal details — cavity closer

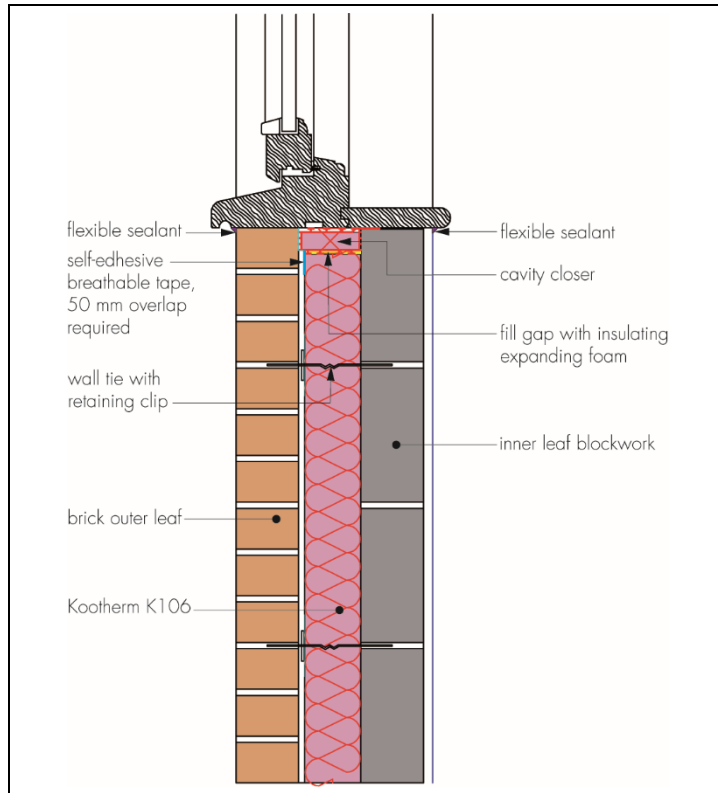

14.14 Additional wall ties at 300 mm vertical centres of all openings are recommended in BS EN 1996-1-1 : 2005 and BS EN 1996-1-2 : 2005. For this product, this would involve piercing the boards and may introduce an unacceptable risk of water penetration. Therefore, it is recommended that an additional wall tie is included within 225 mm of the opening on each board course level to satisfy the structural requirements of the wall (see Figure 6).

Figure 6 Reveal detail with double ties

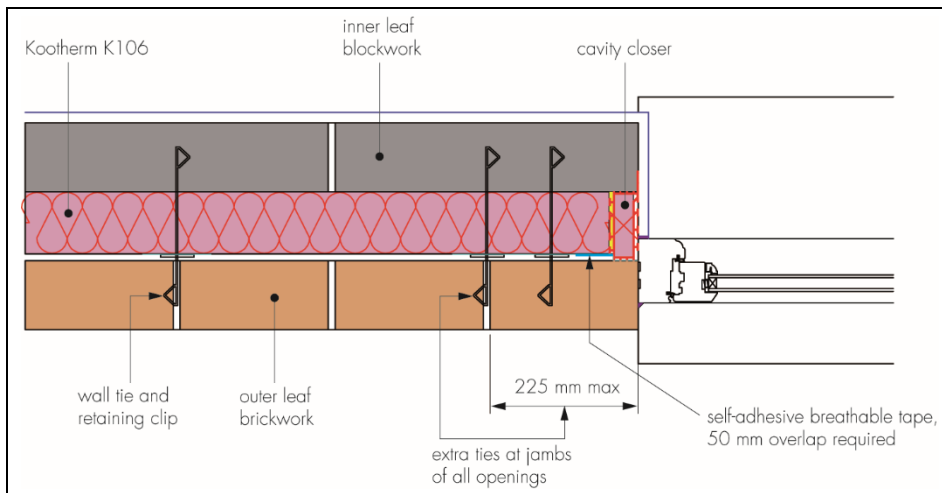

14.15 If, however, the additional wall ties as recommended in BS EN 1996-1-1 : 2005 and BS EN 1996-1-2 : 2005 are used, the self-adhesive breather tape can be used to create a seal around the wall tie penetrations. A vertical slit can be cut in the tape wherever the board has been penetrated by the extra wall ties around the jamb openings. The tape can then be slid over the wall tie in order to make good the penetration so that a weathertight seal is formed. The tape can also be applied by a minimum 25 mm horizontal slit at either end of two separate pieces of tape. The two pieces can then be applied by overlapping them by at least 50 mm (see Figure 7).

Figure 7 Self-adhesive breathable tape applied around wall tie penetrations

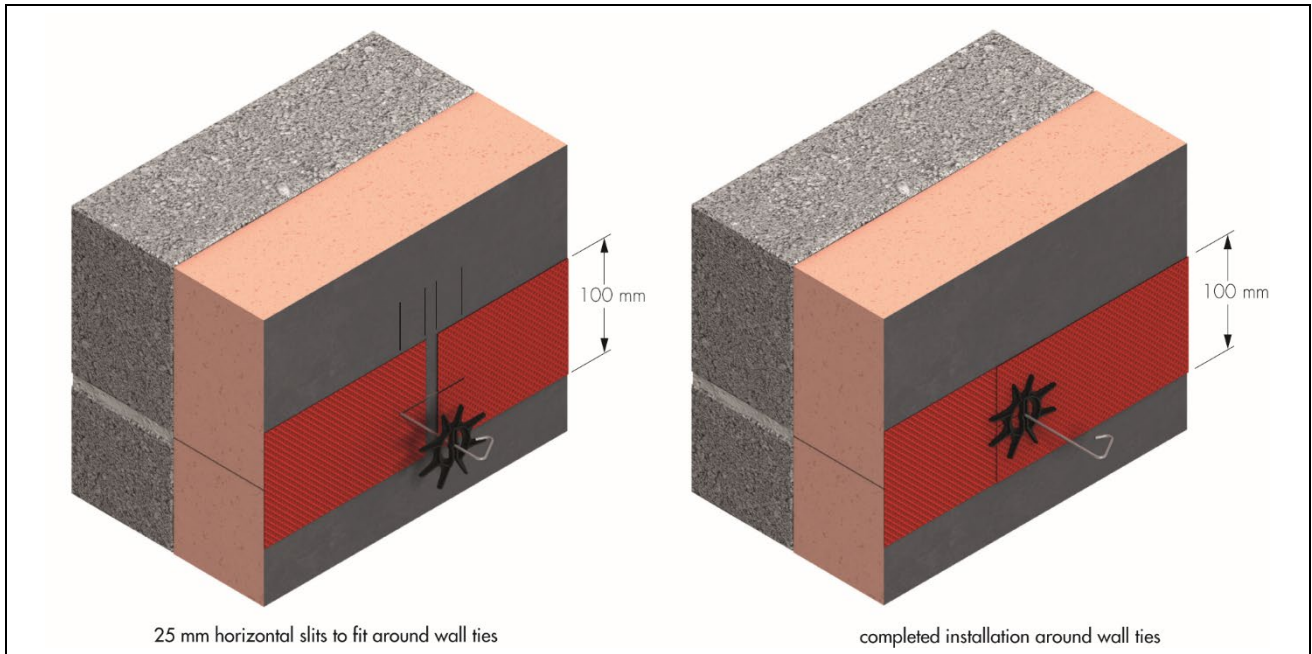

### Corners

14.16 Corner details are formed by cutting the boards squarely and closely butt-jointing, or by cutting board ends at a 45° angle to create a mitred joint, so that all board interfaces are uninterrupted. All corner details incorporate a 100 mm wide self-adhesive breathable tape, as a vertical dpc, so that a minimum 50 mm overlap beyond the board ends (at all courses) is achieved, as shown in Figure 8.

Figure 8 Corner details

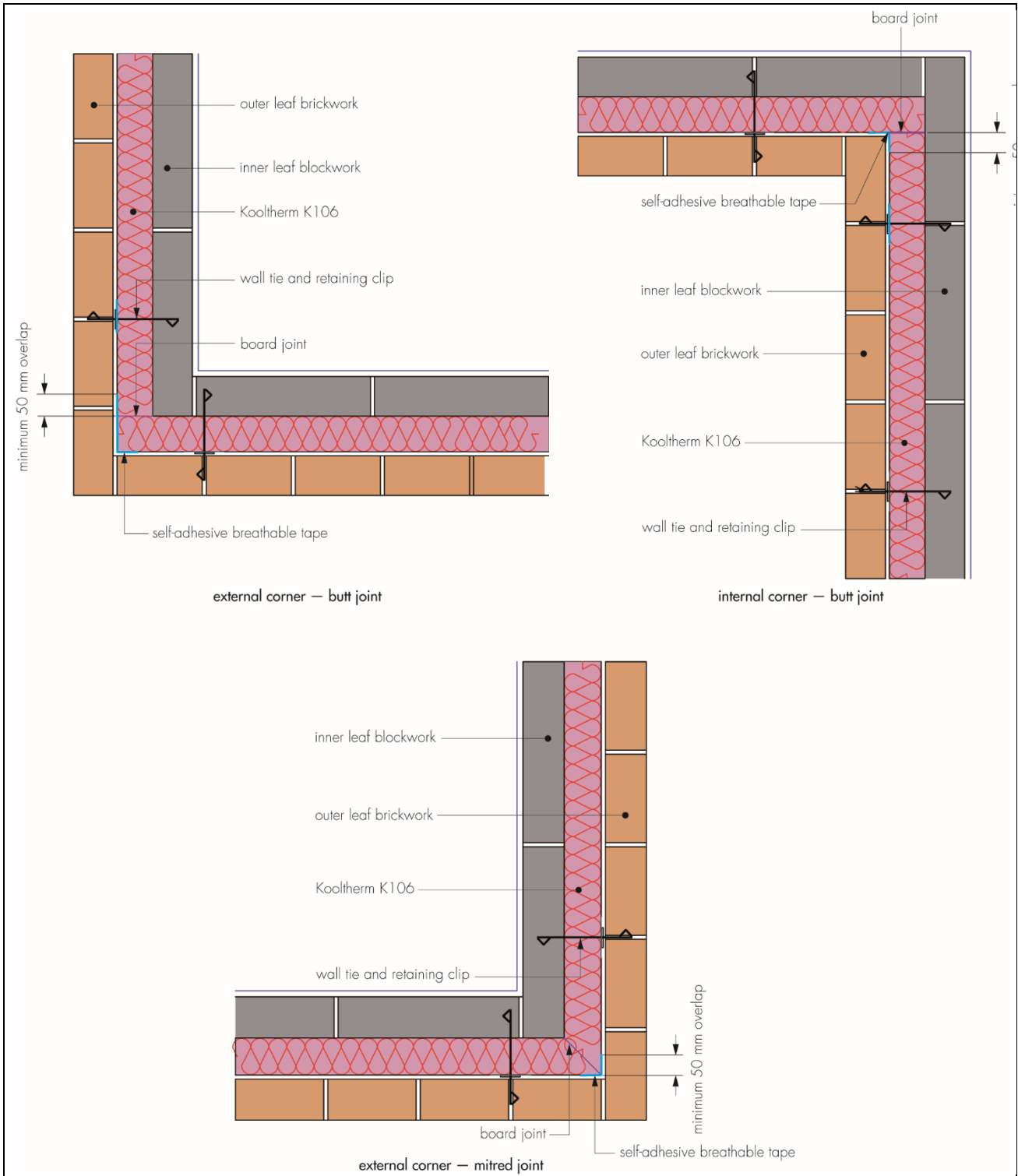

## Protection

14.17 Exposed areas of board should always be covered at the end of a day's work or in driving rain.

14.18 All building involving the product, particularly interrupted work, must conform to BS EN 1996-2 : 2006, Sections 3.2 *Acceptance, handling and storage of materials* and 3.6 *Curing and protective procedures during execution*.

### 15 Tests

Results of tests were assessed to determine:

- resistance to rain penetration of an insulated cavity wall
- thermal conductivity
- dimensional accuracy
- dimensional stability under specific temperature and humidity conditions
- water absorption
- water vapour transmission.

### 16 Investigations

16.1 Existing data on toxicity, durability and properties in relation to fire were evaluated.

16.2 A condensation risk analysis was carried out.

16.3 A series of U value calculations were carried out.

16.4 A calculation was undertaken to confirm the declared thermal conductivity.

16.5 The manufacturing process was examined, including the methods adopted for quality control, and details were obtained of the quality and composition of the materials used.



## Bibliography

- BS 5250 : 2011 *Code of practice for control of condensation in buildings*
- BS 8000-3 : 2001 *Workmanship on building sites — Code of practice for masonry*
- BS EN 845-1 : 2013 *Specification for ancillary components for masonry — Wall ties, tension straps, hangers and brackets*
- BS EN 1996-1-1 : 2005 *Eurocode 6 — Design of masonry structures — General rules for reinforced and unreinforced masonry structures*
- NA to BS EN 1996-1-1 : 2005 UK National Annex to *Eurocode 6 — Design of masonry structures — General rules for reinforced and unreinforced masonry structures*
- BS EN 1996-1-2 : 2005 *Eurocode 6 — Design of masonry structures — General rules — Structural fire design*
- NA to BS EN 1996-1-2 : 2005 UK National Annex to *Eurocode 6 — Design of masonry structures — General rules — Structural fire design*
- BS EN 1996-2 : 2006 *Eurocode 6 — Design of masonry structures — Design considerations, selection of materials and execution of masonry*
- NA to BS EN 1996-2 : 2006 UK National Annex to *Eurocode 6 — Design of masonry structures — Design considerations, selection of materials and execution of masonry*
- BS EN 1996-3 : 2006 *Eurocode 6 — Design of masonry structures — Simplified calculation methods for unreinforced masonry structures*
- NA to BS EN 1996-3 : 2006 UK National Annex to *Eurocode 6 — Design of masonry structures — Simplified calculation methods for unreinforced masonry structures*
- BS EN 13166 : 2012 + A1 : 2015 *Thermal insulation products for buildings — Factory made phenolic foam (PF) products — Specification*
- BS EN 13501-1 : 2007 + A1 : 2009 *Fire classification of construction products and building elements — Classification using data from reaction to fire tests*
- BS EN ISO 6946 : 2007 *Building components and building elements — Thermal resistance and thermal transmittance — Calculation method*
- BS EN ISO 9001 : 2008 *Quality management systems — Requirements*
- PD 6697 : 2010 *Recommendations for the design of masonry structures to BS EN 1996-1-1 and BS EN 1996-2*
- BRE Report (BR 262 : 2002) *Thermal insulation : avoiding risks*
- BRE Report (BR 443 : 2006) *Conventions for U-value calculations*

### 17 Conditions

17.1 This Certificate:

- relates only to the product/system that is named and described on the front page
- is issued only to the company, firm, organisation or person named on the front page – no other company, firm, organisation or person may hold or claim that this Certificate has been issued to them
- is valid only within the UK
- has to be read, considered and used as a whole document – it may be misleading and will be incomplete to be selective
- is copyright of the BBA
- is subject to English Law.

17.2 Publications, documents, specifications, legislation, regulations, standards and the like referenced in this Certificate are those that were current and/or deemed relevant by the BBA at the date of issue or reissue of this Certificate.

17.3 This Certificate will remain valid for an unlimited period provided that the product/system and its manufacture and/or fabrication, including all related and relevant parts and processes thereof:

- are maintained at or above the levels which have been assessed and found to be satisfactory by the BBA
- continue to be checked as and when deemed appropriate by the BBA under arrangements that it will determine
- are reviewed by the BBA as and when it considers appropriate.

17.4 The BBA has used due skill, care and diligence in preparing this Certificate, but no warranty is provided.

17.5 In issuing this Certificate the BBA is not responsible and is excluded from any liability to any company, firm, organisation or person, for any matters arising directly or indirectly from:

- the presence or absence of any patent, intellectual property or similar rights subsisting in the product/system or any other product/system
- the right of the Certificate holder to manufacture, supply, install, maintain or market the product/system
- actual installations of the product/system, including their nature, design, methods, performance, workmanship and maintenance
- any works and constructions in which the product/system is installed, including their nature, design, methods, performance, workmanship and maintenance
- any loss or damage, including personal injury, howsoever caused by the product/system, including its manufacture, supply, installation, use, maintenance and removal
- any claims by the manufacturer relating to CE marking.

17.6 Any information relating to the manufacture, supply, installation, use, maintenance and removal of this product/system which is contained or referred to in this Certificate is the minimum required to be met when the product/system is manufactured, supplied, installed, used, maintained and removed. It does not purport in any way to restate the requirements of the Health and Safety at Work etc. Act 1974, or of any other statutory, common law or other duty which may exist at the date of issue or reissue of this Certificate; nor is conformity with such information to be taken as satisfying the requirements of the 1974 Act or of any statutory, common law or other duty of care.